

FORTNIGHTLY

UK £9.99, EIRE/MALTA €15.99, SA R139.90, AUS/NZ \$19.99 (inc. GST), US \$20.00

EAGLEMOSS
COLLECTIONS

18

STAR TREK™

THE OFFICIAL STARSHIPS COLLECTION



BAJORAN

SOLAR-SAILOR

TYPE: LIGHTSHIP

LAUNCHED: 16th C

CREW: 2

NUMBER OF DECKS: 1

Contents

P04: BAJORAN SOLAR-SAILOR

P10: THE BAJORAN SYSTEM

P12: DESIGNING THE SHIP

P18: ON SCREEN

Stand assembly:

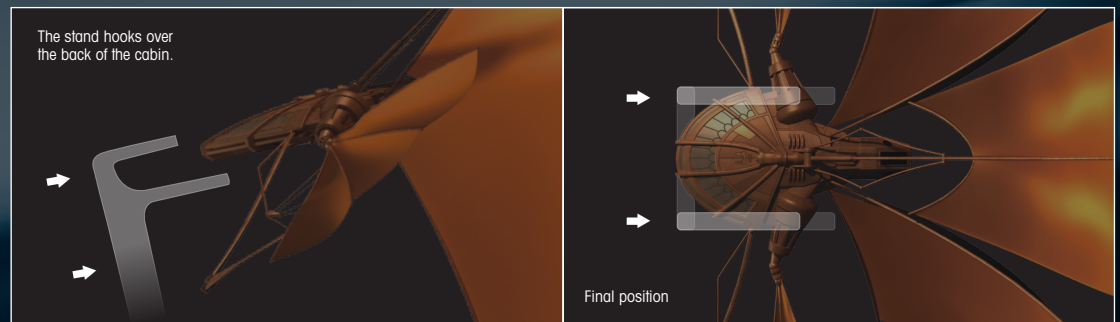

EAGLEMOSS COLLECTIONS

Eaglemoss Publications Ltd. 2014
1st Floor, Kensington Village, Avonmore Road,
W14 8TS, London, UK. All rights reserved.

™ & © 2014 CBS Studios Inc. STAR TREK and related
marks and logos are trademarks of CBS Studios Inc. All
Rights Reserved.

Development Director: Maggie Calmels

YOUR COLLECTION STAR TREK – The Official Starships
Collection is published fortnightly.

DON'T MISS AN ISSUE

To make sure you receive every issue, take out
a subscription and get STAR TREK – The Official Starships
Collection delivered direct to your door or place a regular
order with your magazine retailer.

SUBSCRIPTIONS

When you subscribe you will receive exclusive free gift!
To subscribe:

Visit our website at www.startrek-starships.com
Call our hotline 0844 493 6091

Post the subscription form (which you will find inside issues
1, 2, 3, 4 & 5)

BACK ISSUES

To order back issues: Order online at
www.startrek-starships.com or call 0844 493 6091

UK distributor:
COMAG Magazine Marketing

UK CUSTOMER SERVICES

Call: 0844 493 6091

Email: startrek-ship@eaglemoss-service.com

Write to: STAR TREK – The Official Starships Collection,
Database Factory, Unit 4, Pullman Business Park, Pullman
Way, Ringwood, Hampshire, BH24 1HD

Australia

Call: (03) 9872 4000

E-mail: bissett@bissettmags.com.au

Write to: STAR TREK – The Official Starships Collection,
Bissett Magazine Service Pty Limited, PO Box 3460
Nunawading, VIC 3131

New Zealand

Call: (09) 308 2871

Fax: (09) 302 7661

Email: subs@ndc.co.nz

Write to: STAR TREK – The Official Starships Collection, Netlink
Subscriptions, PO Box 47-906, Ponsronby, Auckland

South Africa

Call: (011) 265 4307

E-mail: service@jacklin.co.za

Write to: STAR TREK – The Official Starships Collection,
Eaglemoss Publications Ltd, Private Bag 18, Centurion
0046

Malaysia

Call: (03) 8020 7112

E-mail: sales@allscript.com

Write to: STAR TREK – The Official Starships Collection,
Allscript Establishment (M) Sdn. Bhd. No. 16, Jalan TP
3, Taman Perindustrian SIME UEP, 47620 Subang Jaya,

Salangor Darul Ehsan, Malaysia

Singapore

Call: (65) 6287 7090

E-mail: sales@allscript.com

Write to: STAR TREK – The Official Starships Collection,
Allscript Establishment,
605A Macpherson Road, #04-04, Citimac Industrial
Complex, Singapore 368240

OVERSEAS BACK ISSUES

Place your order with your local magazine retailer.

Recommended age 14+.

Warning! Collectable figurines.

Not designed or intended for play by children.

Do not dispose of in domestic waste.

 **Find us on
Facebook**

Join us online for competitions, updates and more!



**STORE YOUR
COLLECTION
in these binders**

TO PLACE AN ORDER,
GO ONLINE AND VISIT:

www.startrek-starships.com

www.startrek-starships.com

BAJORAN
SOLAR-SAILOR

BAJORAN SOLAR-SAILOR

SPECIFICATION

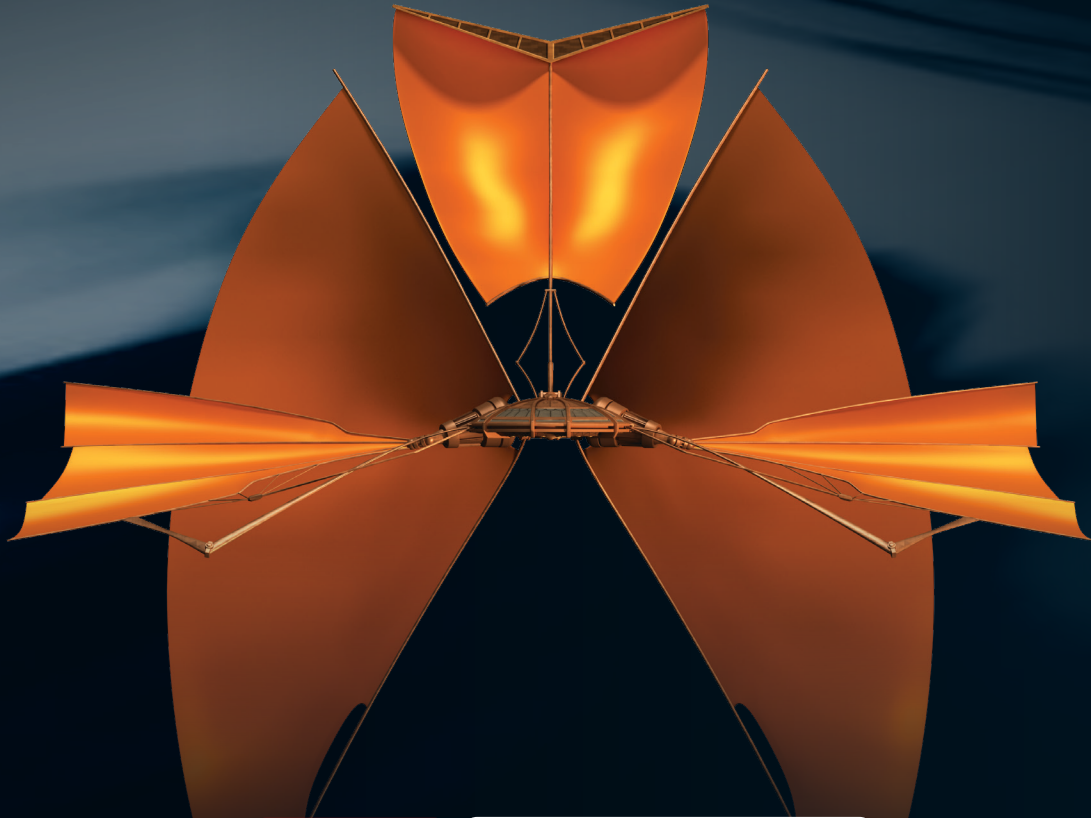

TYPE:	LIGHTSHIP
IN OPERATION:	16th CENTURY - 22nd CENTURY
DECKS:	1
CREW:	2
WEAPONRY:	NONE
POWERED BY:	SOLAR SAILS
TOP SPEED:	SUBLUMINAL BUT WARP POSSIBLE VIA TACHYON EDDIES

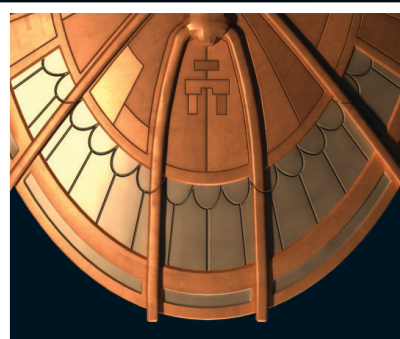

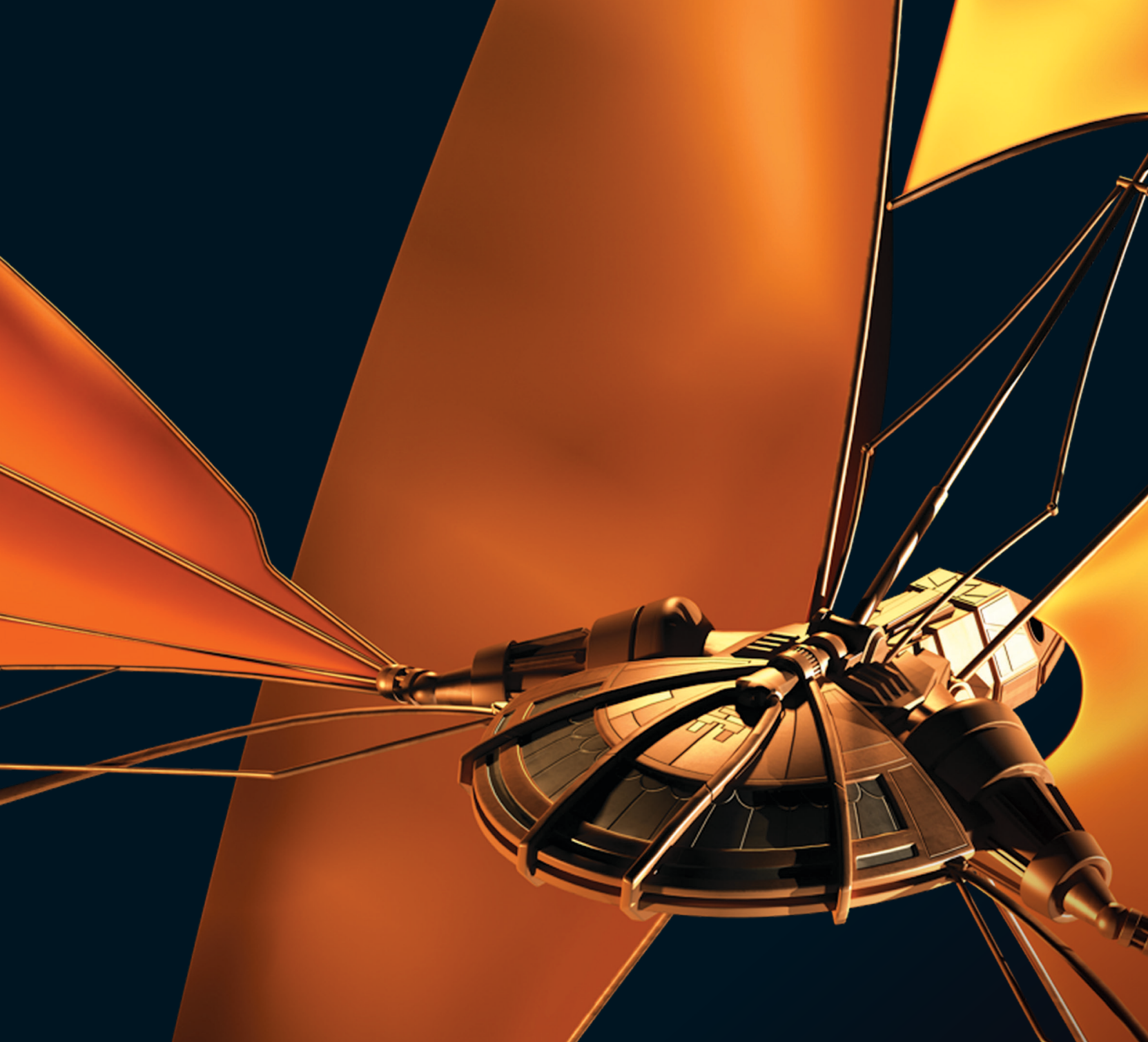

BAJORAN
SOLAR-SAILOR

Ancient Bajorans used these simple solar-sail powered spacecraft to explore their star system and beyond.

DATA FEED

Many believed that the ancient Bajorans could not have travelled very far in their solar-sailor vessels because they would need to have passed through the Denorios Belt. This was an unstable region of space in the Bajor system filled with severe neutrino disturbances and tachyon eddies, as well as being the location of the Bajoran wormhole.

Bajoran solar-sailor vessels were ancient spacecraft that used enormous reflective sails to harness the power of light pressure from Bajor's sun to provide propulsion, much in the same way as a sailboat does with the wind.

More than 800 years ago, when humans were first sailing across oceans, the Bajorans used these solar-sailor vessels, or lightships, to explore their star system. It was believed by some historians that these ancient vessels even managed to reach Cardassia in the neighbouring star system, but as these fragile ships were not designed for faster-than-light travel it was thought unlikely this was possible.

In 2371, Benjamin Sisko became fascinated by these ancient lightships after seeing blueprints for them while visiting the reopening of an old library on Bajor that had the most extensive collection of antiquities on the planet. He decided to use these plans to build an authentic replica of a solar-sailor vessel to see if it was spaceworthy.

Certainly, Chief Miles O'Brien was skeptical that it would work, and he was sure that it could not have made it all the way to Cardassia. He pointed out that at sublight speeds the journey would have taken years, and the limited room on board the vessel meant the air supply would only last a few weeks. He also doubted the fragile ship would have survived the expedition, as encountering any kind of ion storm would have torn the sails to pieces and left the ship stranded.

TRADITIONAL CONSTRUCTION

Despite O'Brien's doubts, Sisko pressed on with the project, building the solar-sailor vessel in one of *Deep Space 9's* cargo bays using the same materials and tools as the ancient Bajorans had done. In just a few weeks Sisko completed the vessel, impressing his colleagues with the fine, detailed craftsmanship that went into its construction. The only concession to modern

▲ Sisko built an exact replica of a solar-sailor vessel that the Bajorans used as early as the 16th century. They included a small living capsule surrounded by enormous solar-wind sails. The ships featured elegant craftsmanship, but were also fragile and not designed for faster-than-light speeds.

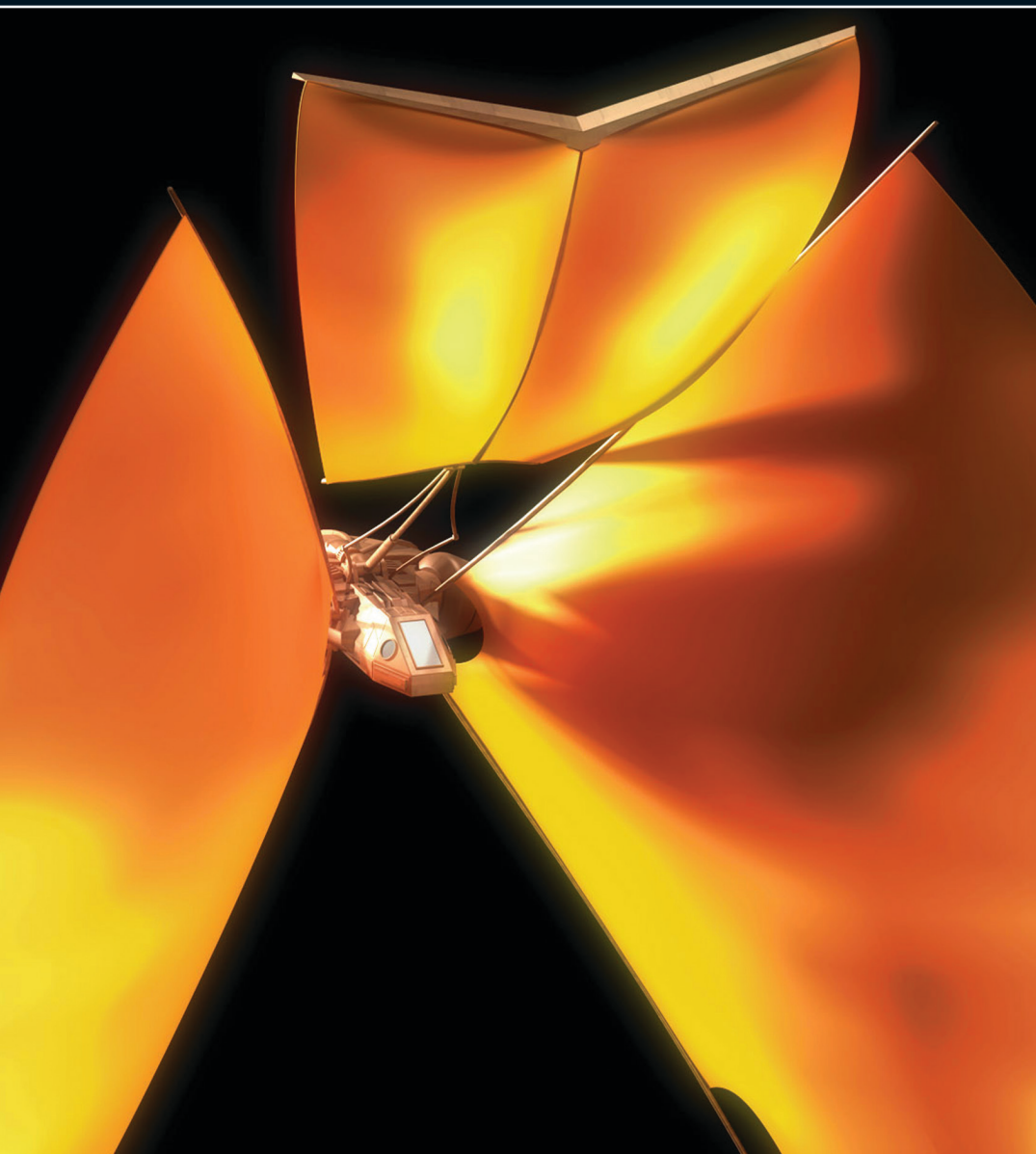

◀ Once all its sails were deployed, the solar-sailor looked like a cross between a daddy longlegs and a butterfly.

▼ When the starboard spritsail became damaged, Sisko was forced to jettison it by detonating a small charge at the base of the mast.



technology that Sisko made was to install a gravity net in the floor, as weightlessness made him feel sick.

After launching from *Deep Space 9*, it did not take them long to get the sails in position, catch the light pressure from the Bajoran sun and start to sail across the star system. Even Jake, who had initially been reluctant to join his father on the trip, was struck by the romanticism of the mode of transport as the ship sailed silently and serenely among the stars.

The solar-sailor initially performed very well, but part way through the journey the support for the starboard spritsail gave way and it ended up blocking one of the mainsails. Unable to fix it, Sisko was forced to jettison the spritsail by detonating a small charge at the base of its support. The ship

was now no longer running as smoothly as it had done before, but Sisko and his son were determined not to let this setback end the journey and they decided to press ahead.

WARP SPEED

The solar-sailor had not gone much further when it was hit by a powerful force that tore the port mainsail clean off and catapulted the ship forward at warp speed.

It transpired that the vessel had been caught in a tachyon eddy, a naturally-occurring phenomenon common in the Bajoran system, that scooped it up and propelled it at faster than light speeds. Normally, tachyon eddies were not powerful enough to affect spaceships, but because the solar-



▶ Jake was slightly shocked and amused by how small the ship's 'head' or bathroom was. It was barely big enough for him to fit inside.

◀ The interior was full of exquisitely crafted materials, but it was cramped. The winch assemblies were used to unfurl and control the sails. The angle of the sails and thus direction of travel could be altered by subtle adjustment of the winches.

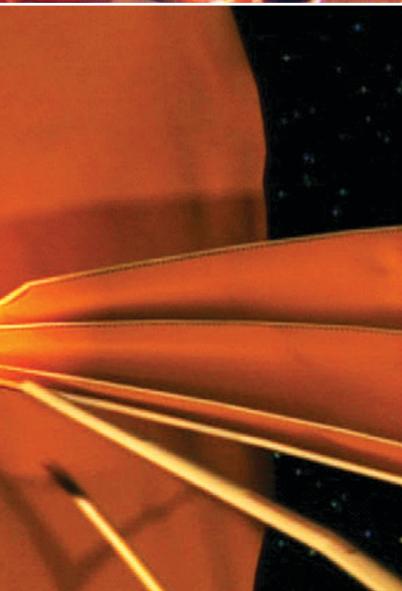

◀ Three Cardassian warships put on a fireworks show as they begrudgingly celebrated the achievement of Sisko's solar ship.

sailor had a large surface-area-to-mass ratio, their impact on the sails accelerated it to warp speed.

By the time the solar-sailor was ejected from the tachyon eddy, it had travelled several light years, and Sisko and Jake initially had no idea where they were. It was only when three Cardassian warships appeared that they realised they had been flung clear across the Denorios Belt and all the way to the Cardassian system.

Sisko and Jake had proved that it was possible for the solar-sailor vessels to have reached as far as Cardassia. In a suspicious coincidence, it was only then that the Cardassians admitted that they had recently found the remains of a Bajoran lightship on Cardassia, proving beyond doubt that these ancient vessels were capable of interstellar flights.



DATA FEED

As a Starfleet officer in charge of *Deep Space 9*, Sisko had little time for outside interests. Prior to his appointment at the space station, he had a background in engineering and served at the Utopia Planitia Fleetyards where, among other things, he helped develop the *U.S.S. Defiant NX-74205*. It was only natural that he jumped at the chance to build a *Bajoran solar-sailor* and indulge his passion for ship design. Many of his colleagues remarked on how happy he was working on the project and how well he built it.

INSIDE THE SOLAR-SAILOR

The interior of the solar-sailor was small and cramped with a low ceiling, but the use of rich woods and ornate metal work for the pipes, valve assemblies and analogue gauges made it a cozy, elegant environment.

The finish of the fittings in the interior may have been lavish, but it was sparsely furnished. There were no chairs or beds, and when it came time to sit or sleep, the crew had to perch wherever they could find space or string up a hammock. The one piece of furniture in the interior was a small table where star charts could be unrolled and laid out, while a sextant fastened to the wall was used for navigation.



▲ The interior had beautifully crafted fixtures, but it was sparsely furnished as the crew had to work the winches for the sails.

DATA FEED

The Bajorans used solar-sailor vessels to explore their region of space as early as the 16th century. This was 400 years before humans had achieved any type of manned spaceflight.

Solar spritsail

Spritsail mast

Solar jib sail

Living capsule

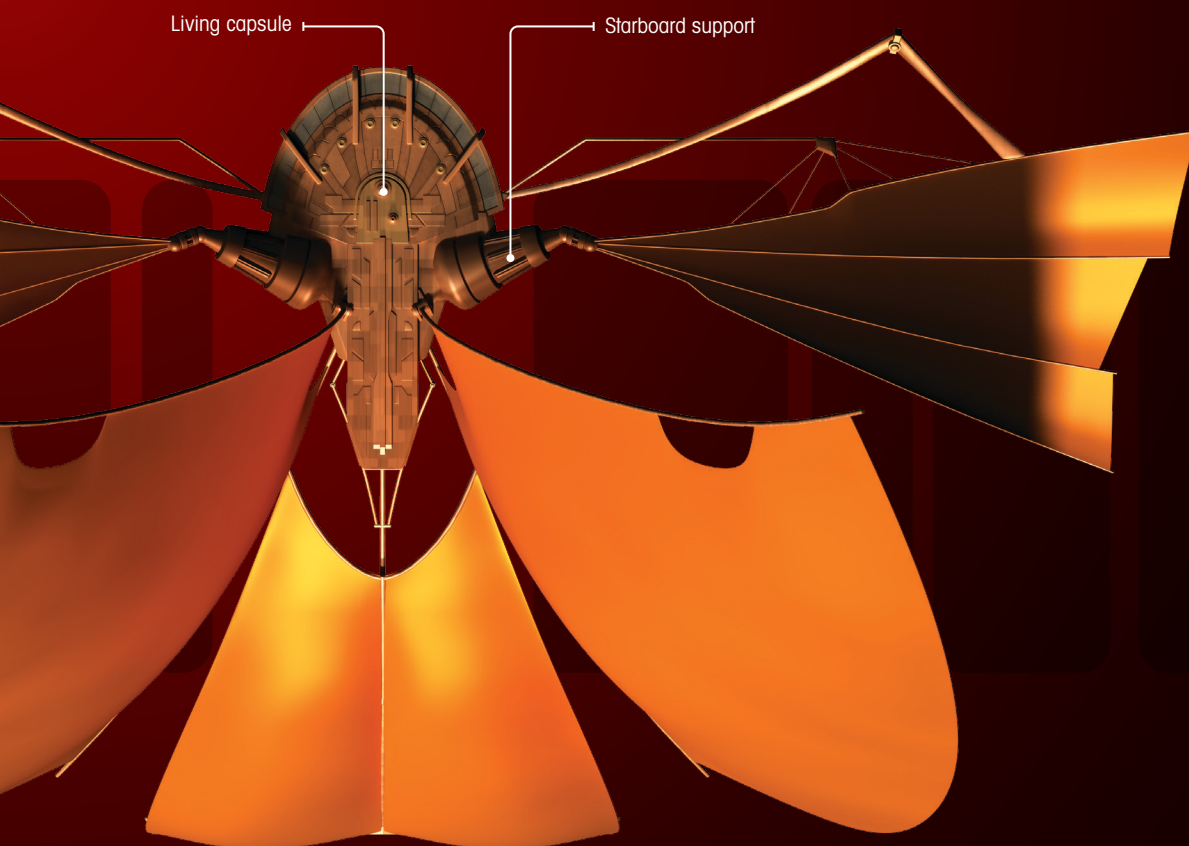
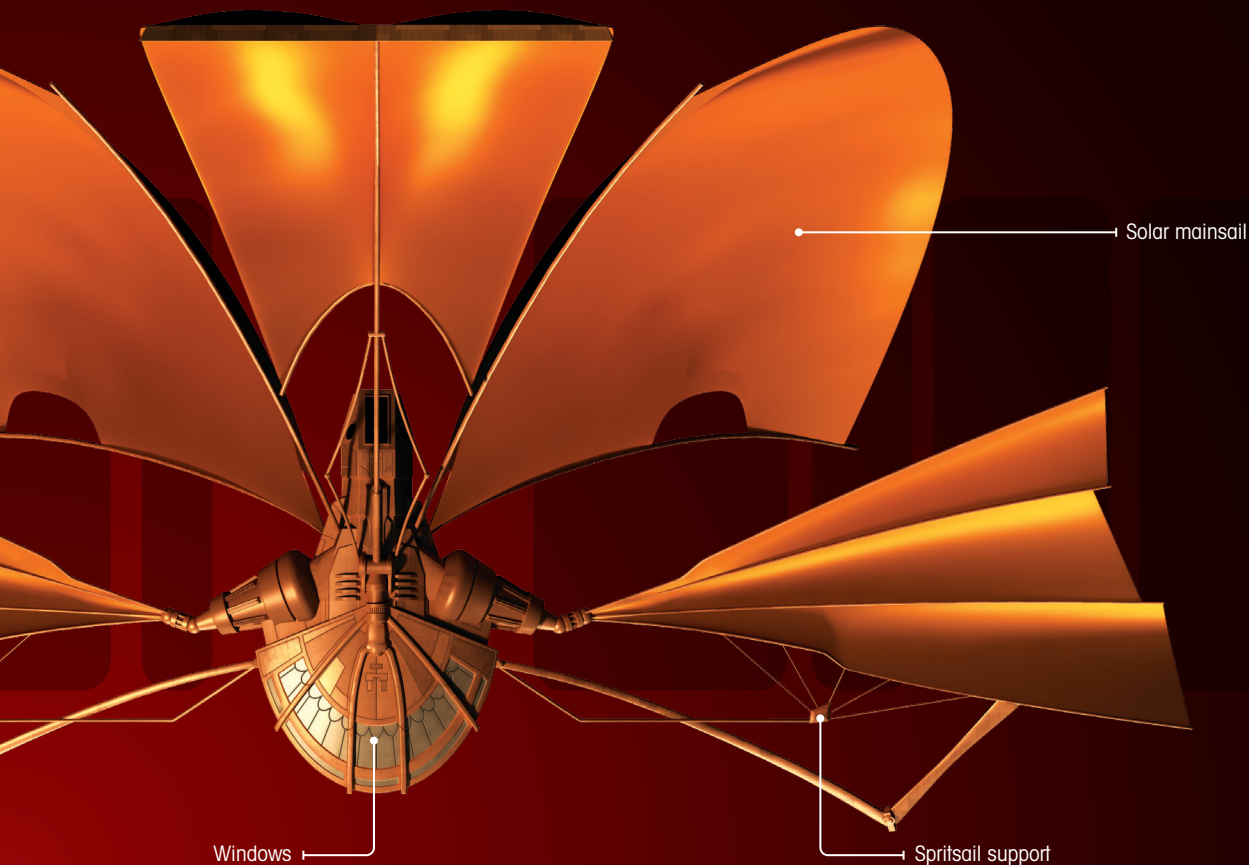

STAR TREK FIRST

The first ever mention of a bathroom in *STAR TREK* history is made in the episode that features the *Bajoran solar-sailor*, when Jake Sisko commented on the compact size of its facilities.

POET & PROPHETS

Bajoran poet Akorem Laan was travelling in a *Bajoran solar-sailor* in 2174 when it was damaged by an ion storm and drifted into the Bajoran wormhole. The Prophets returned him to the Alpha Quadrant two hundred years later in 2372.

TACHYON POWER

Tachyons are particles that are always travelling faster than light. They are often associated with time travel, but in the case of the solar sailor an interstellar current of these particles swept it to warp speeds and into the Cardassian system.

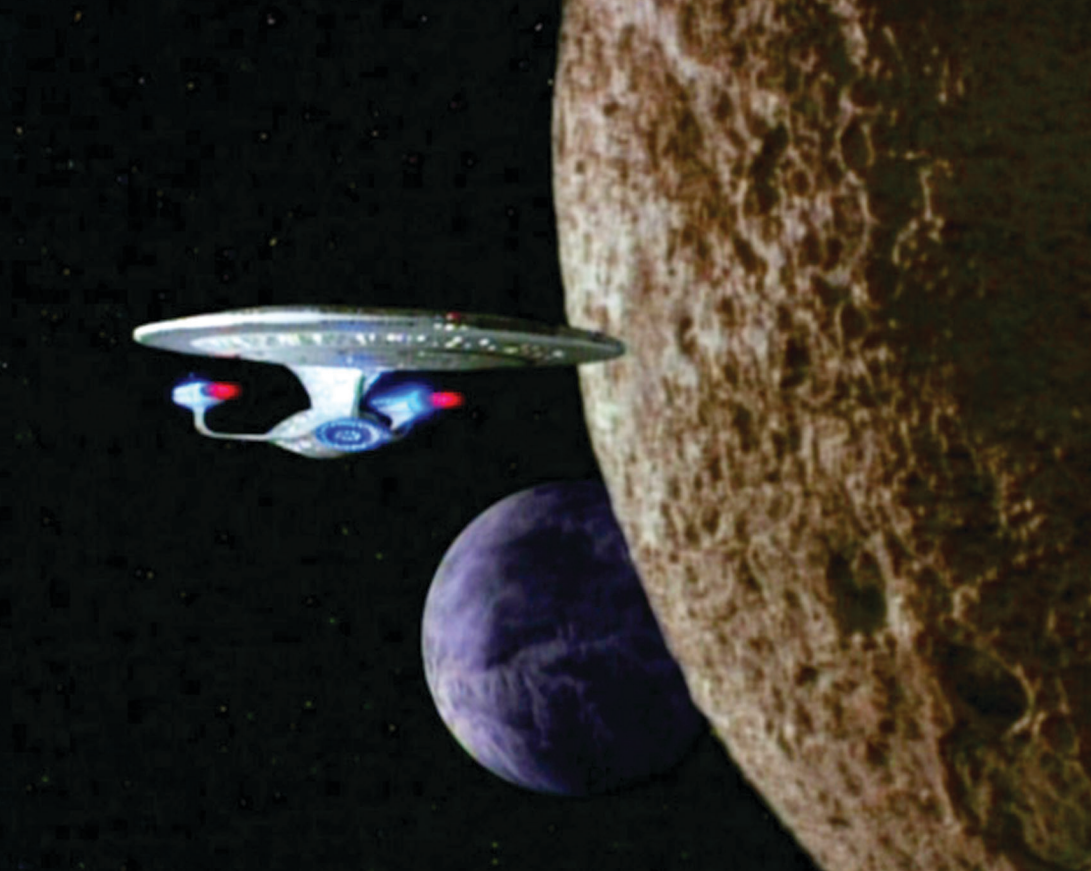

THE

▲ The Bajoran system contains 14 planets, most of which are rich in natural resources. Bajor's homeworld is the 11th planet in the system.



BAJORAN SYSTEM

The Bajoran system is located approximately 50 light years away from the core Federation worlds, far deeper into the Alpha Quadrant than Earth's Sol system. The closest neighbouring systems are Cardassian space and the Valo system, located in neutral space very close to the Cardassian border, and containing at least three habitable planets.

At five and a quarter light years, the Bajoran system was once a safe distance from Cardassian space. The development of warp drive, however, ultimately led to the Cardassians reaching Bajor, where they plundered the Bajorans' rich natural resources having exhausting their own reserves.

Archaeological finds on Cardassia Prime proved that Bajorans were successful in crossing the dangerous

Denorios Belt between the two systems eight centuries earlier. This was done in relatively flimsy vessels that used solar sails for power – an impressive engineering and navigational feat.

EXTENSIVE SYSTEM

The central star of the Bajoran system is Bajor-B'hava'el, which has 14 planets revolving around it. These include eight terrestrial worlds, of which Bajor XI is the primary homeworld; three gas giants; and three ice/rock conglomerates. In the case of Bajor, its rich deposits of uridium were one of the primary reasons for Cardassian occupation, and for the construction of processing facilities, such as *Terok Nor* and *Empok Nor*.

The second inhabited planet within the system is Bajor VIII, consisting of six colonies and at least two moons.

Smaller Bajoran colonies are also located on Free Haven, although their future was severely threatened by an attack by Breen privateers in 2372.

Dreon VII is one of the furthest Bajoran colonies regularly visited by freighters from Bajor, with Prophet's Landing being the Bajoran colony closest to the Cardassian border, and large enough to warrant its own governor.

The Bajoran system is most renowned for containing temporal anomalies and astronomical phenomena. One of the most fascinating areas is the Denorios Belt, a charged plasma field which contains unusually severe neutrino disturbances and tachyon eddies.

The Denorios Belt is also the location of the artificially created, verteron-driven phenomenon known as the Bajoran wormhole, which allows vessels



▲ The Bajoran wormhole became the most strategically important location in the Alpha Quadrant.

▲ *Deep Space 9* was initially called *Terok Nor* and built by the Cardassians to process minerals stripped from Bajor.

The Bajoran system included some unusual space phenomena, including the Denorios Belt, the home of the Bajoran wormhole.

to travel to the Gamma Quadrant almost instantly. It is referred to by the spiritual Bajoran people as the Celestial Temple, and they looked upon its discovery as absolute proof of the Prophets' existence.

It made the Bajoran system one of the most important regions in the Alpha Quadrant for the economic and scientific opportunities it offered with

the Gamma Quadrant, but contact with the Dominion changed all that.

KEY LOCATION

The Bajoran system suddenly became a key strategic position in the war with the Dominion that followed. The whole system came under severe threat, never more so than in 2373 when a Changeling posing as Dr. Julian Bashir

attempted to destroy the Bajoran sun with a trillithium explosive device.

Following the end of the Dominion War in 2375, Bajor applied to join the Federation. It was hoped that with their help, the Bajorans could use the rich natural resources of their system to rebuild their society that had suffered so much, first at the hands of the Cardassians and then the Dominion.

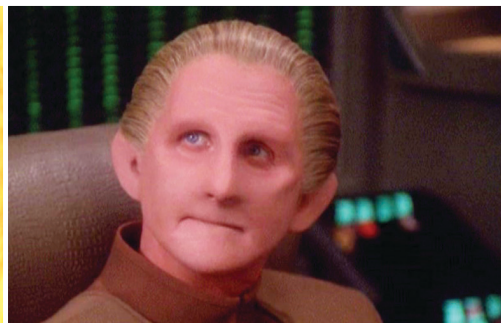
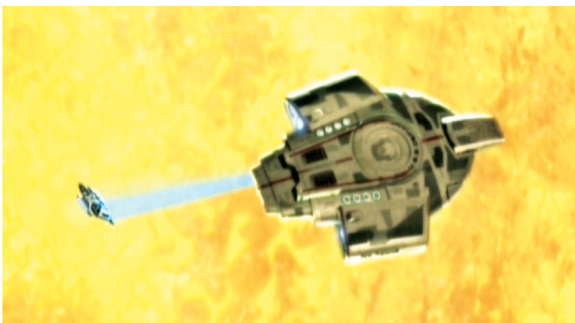

▲ In 2373, a Changeling posing as Dr. Bashir stole a *runabout* and tried to destroy the Bajoran sun.

▲ The Changeling Odo was found adrift as an infant in his natural gelatinous state inside the Denorios Belt.

▲ Derna, Bajor's fourth moon, was used as a field hospital for Romulan troops during the Dominion War.

► Unusually for *STAR TREK*, the *Bajoran solar-sailing ship* had an organic design that Herman Zimmerman described as having a “Jules Verne” feel.

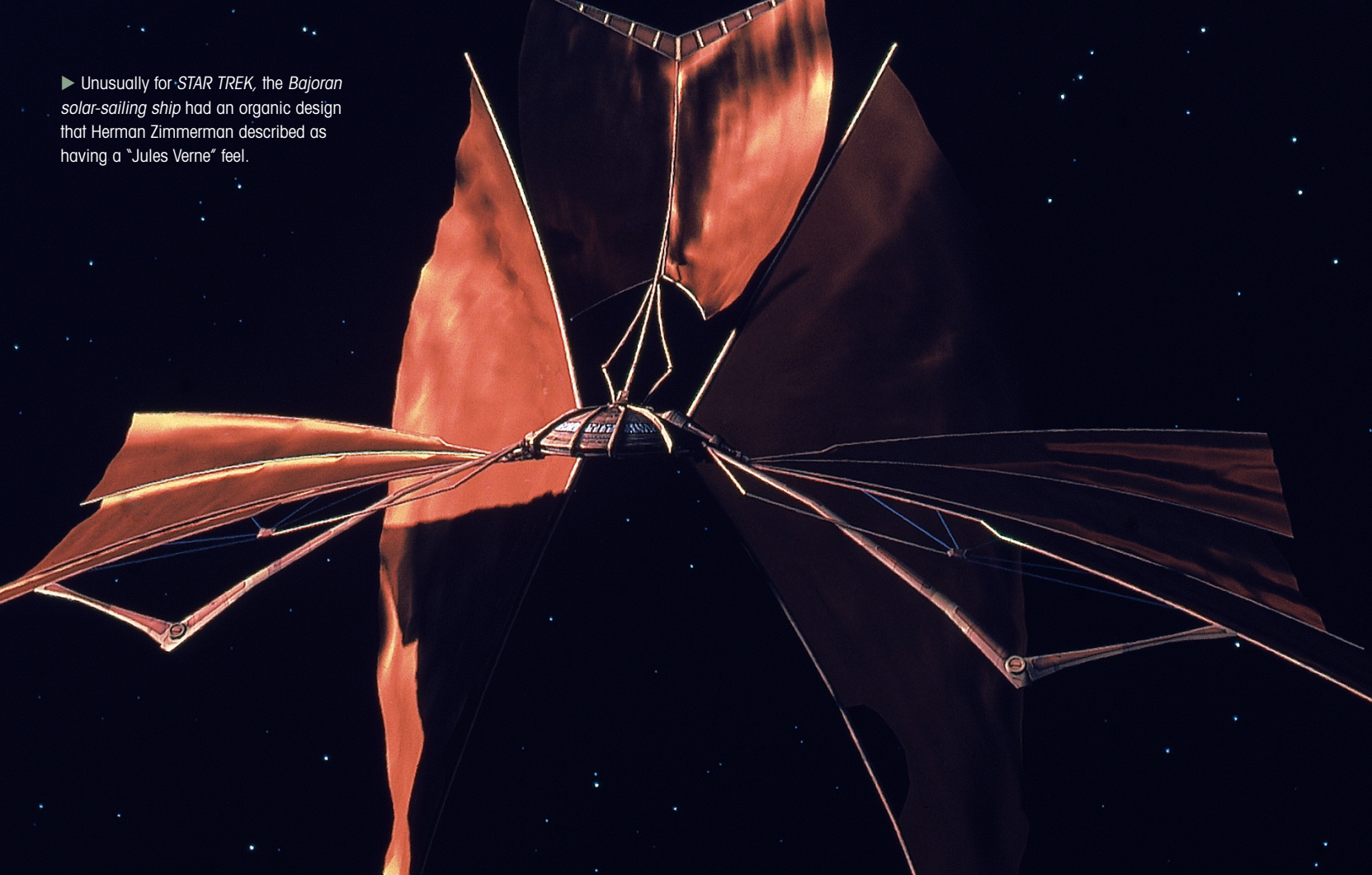

DESIGNING THE



BAJORAN SOLAR-

The Bajoran solar-sailing ship was a radical design departure that owed as much to Jules Verne as the *U.S.S. Enterprise*.

The *Bajoran solar-sailor ship* was one of the most unusual and elegant vessels to appear on *STAR TREK*. It was specially designed for the third season *STAR TREK: DEEP SPACE NINE* episode ‘Explorers’. In the story, Sisko found the plans for an ancient craft in a Bajoran library and decided to build one to prove that it could make an interstellar journey.

The solar-sailor had its origins in Bajor’s past, and because it used solar winds

for propulsion, the art department knew that it needed to look quite different from anything they had designed before. Fortunately, as concept artist Jim Martin remembered, they had some advance warning and time to prepare.

EXTRA TIME

“Normally when there’s an element in a script that is going to need some special design we will find out from the writers very much ahead of time, maybe two

to three weeks,” said Martin. “They’ll let us know that something like the *Bajoran solar-sailor* is coming down the pipe so we have more time to start coming up with ideas. We found out from René Echevarria, who wrote the script, that this was going to be a father/son episode with Sisko and Jake, and they were going to make a solar-sailor. It got us excited.”

Normally when a ship was only needed for one episode there was little

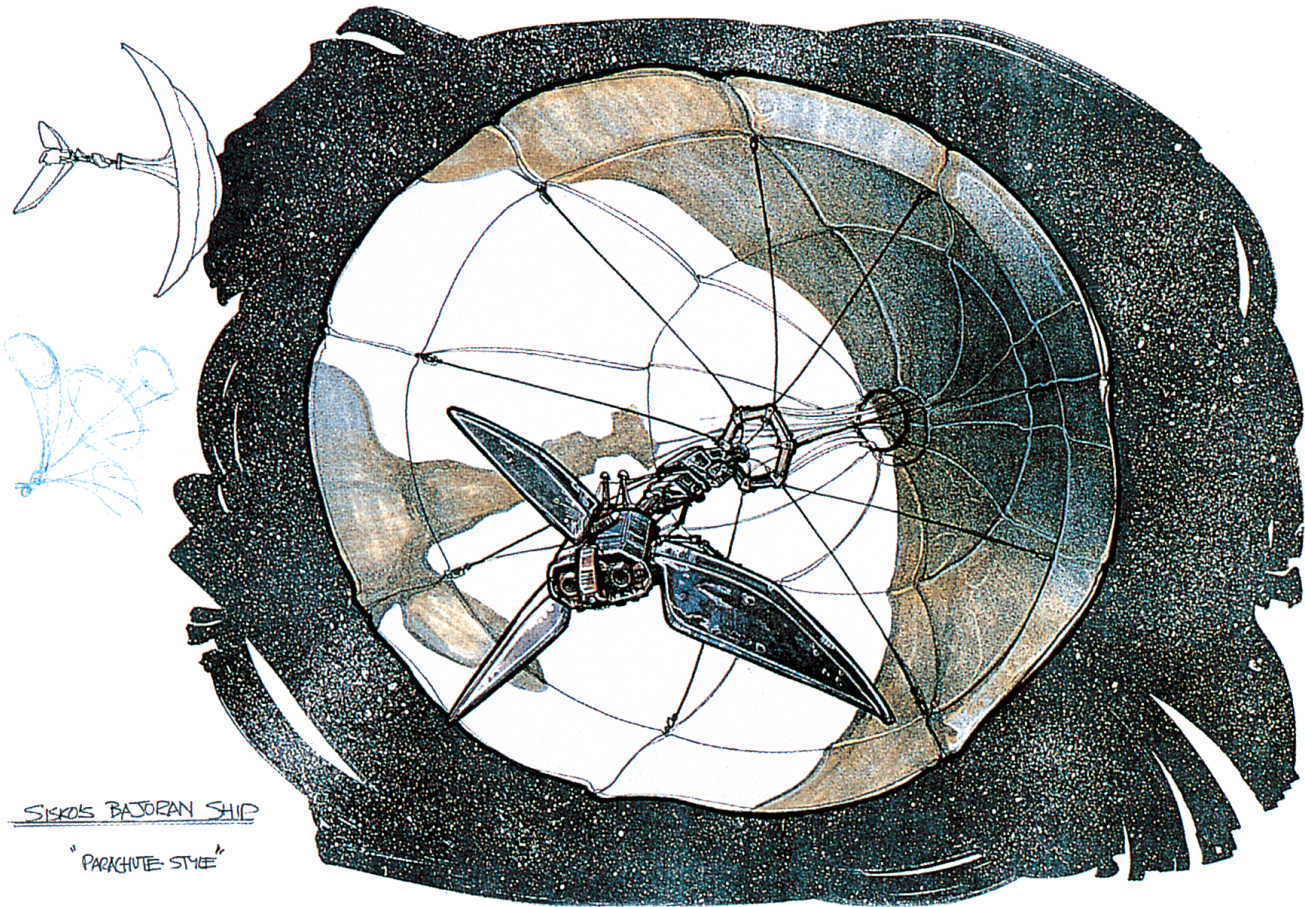

▲ Jim Martin began by sketching out a few different ideas showing how a solar-sailing ship might work. One of his first ideas involved using a parachute-style device attached to the front of the ship.

SAILOR SHIP

scope to design anything special, but this time, Martin said, the brief allowed them to be creative.

"There's a lot of recycling of ships that have been used before, dressed differently for different cultures, so there isn't really a chance to do a lot of new things if it's just going to be a one episode ship," said Martin. "But, because this was very specific about what the design had to be, we needed to come up with something new – it was a nice treat."

As production designer Herman Zimmerman explained, he and Martin began by thinking how a solar-sailing

ship would work. "The original script talked about a means of propulsion which uses the ions in space to propel a craft, which would in layman's terms be the solar wind. The writer indicated that the ship was propelled by huge expanding solar sails that took advantage of the direction of the wind similar to the way a sailboat works on the oceans of the Earth.

"It was a fairly direct approach except that in space you're not sailing on a fluid that's underneath you, you're sailing in a hydrogen-enriched vacuum; in space that is all around you, so the sails couldn't be just above the ship –

they would have to be deployed outward in a circular fan shape."

SCIENCE & FANTASY

Knowing that he had to incorporate these sails, Martin sat down and began to sketch out some ideas. He says that at first he tried to come up with a ship that was scientifically practical. "We did do some things with very large sails," said Martin, "because, obviously, a solar-sailor would need massive solar collectors to even be feasible." Then, during the pre-production process, the producers made a subtle modification to the way the ship worked; instead of

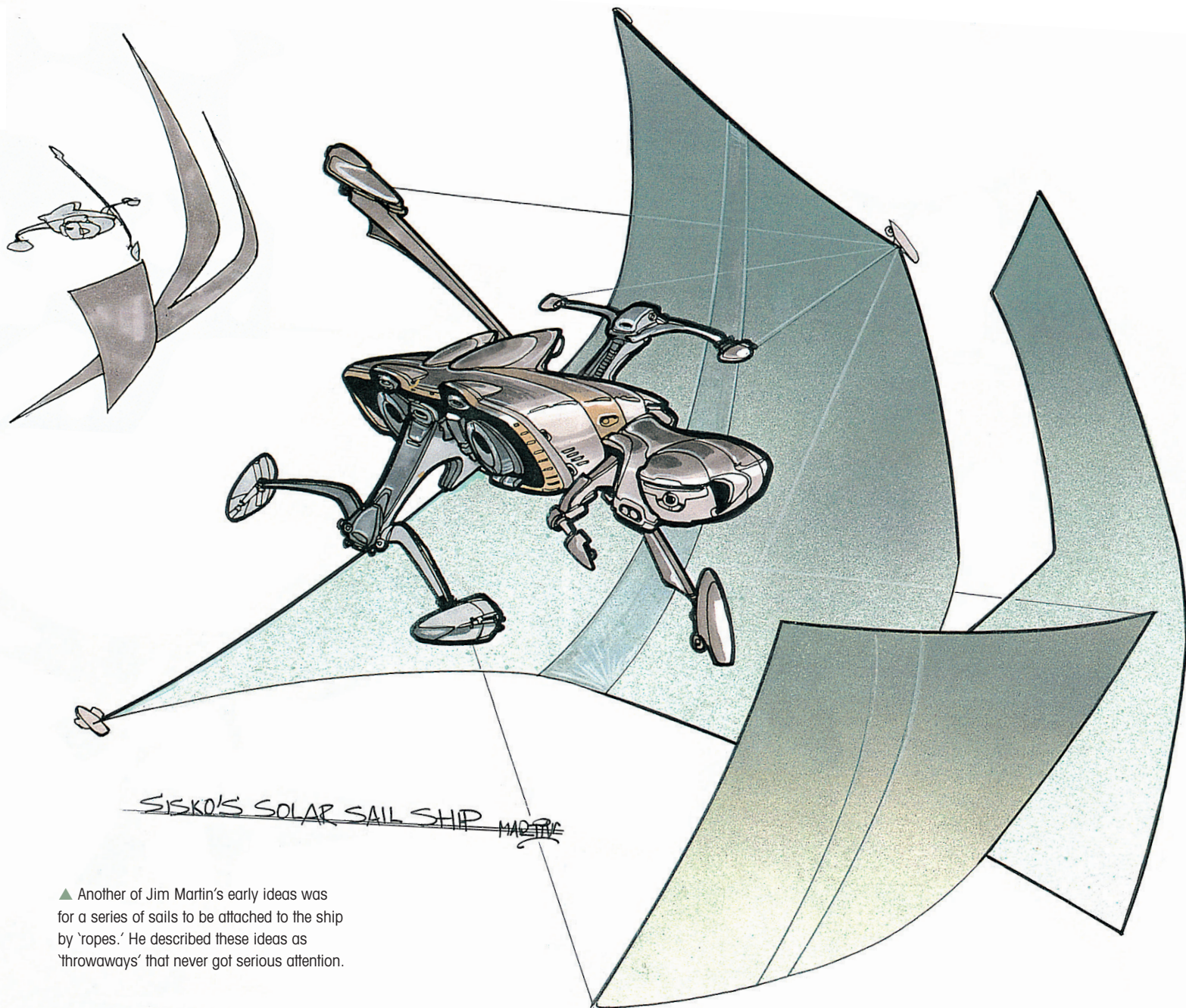

▲ Another of Jim Martin's early ideas was for a series of sails to be attached to the ship by 'ropes.' He described these ideas as 'throwaways' that never got serious attention.

being propelled by ions, which really exist, it used tachyons – hypothetical faster-than-light particles that were often used in *STAR TREK* episodes.

The change may not seem that important, but it had a major influence on the design. Since nobody could say exactly how tachyons worked, Martin and Zimmerman felt that they did not have to be too concerned about the science behind how it worked. In fact, they abandoned the whole idea of looking scientific in favour of a more aesthetic, romantic approach. Martin

was delighted with this new, more organic direction, which rapidly led to the final design.

ELEGANT BUTTERFLY

"It was a nice change to do something that was more fantasy and less science," said Martin. "This was going to be a ship very much in the fantasy realm, as opposed to the hardware of a starship, so it was always going to be elegant instead of practical. I think my first reaction as an illustrator was to do something symmetrical, and to play on

the idea of wings – sails as wings. We did do some different things, but I think that's what everyone was thinking right off the bat, and that's what it ended up being. It's essentially butterfly-like."

Zimmerman explained that they did not consciously set out to make the ship look like a butterfly; it was simply a fortunate accident. "The ship has a very insect-like quality while not being intentionally modelled after an insect. It was a fragile ship from Bajor's ancient past, and that made the challenge very sweet because we were able to go

backwards from the future and reinvent what ancient Bajoran science was. That was fun.”

BAJORAN STYLE

That Bajoran design ethic had a profound effect on the finished ship. Martin said, “The Bajoran stuff is gentle and elegant and ornate. Also, it’s supposed to be a ship from far in the past; I think as humans we look back on earlier designs and a more elegant age, and you put that into the Bajorans too.”

Zimmerman went on to add, “The Bajoran influence made it more

romantic; it was kind of a Jules Verne approach crossed with the Bajoran motif, which was basically a combination of Eastern cultures. If you look at the design, you’ll see a lot of pierced work where the inside and the outside are the same structure. It’s typical, I think, of Japanese architecture to see the structure and not to hide it.”

Once the ship had been designed, it was handed over to Dan Curry’s VFX team. Although at that point most *STAR TREK* ships were made as practical models, they decided that the best way to handle the *Bajoran solar-sailor* was to

build it as a computer-generated model; this made it far easier to manipulate the sails as they billowed in the solar wind. Martin remembered being particularly impressed with the results this produced.

“One of the really nice touches that the digital people did to it was to have the sails unfold as it launches. We talked about it doing that, but there were never any drawings done for the unfolding in the art department; we just kept saying, ‘Yeah, and then it’s going to unfold,’ and I believe that’s because it was in René’s (Echevarria) script. So

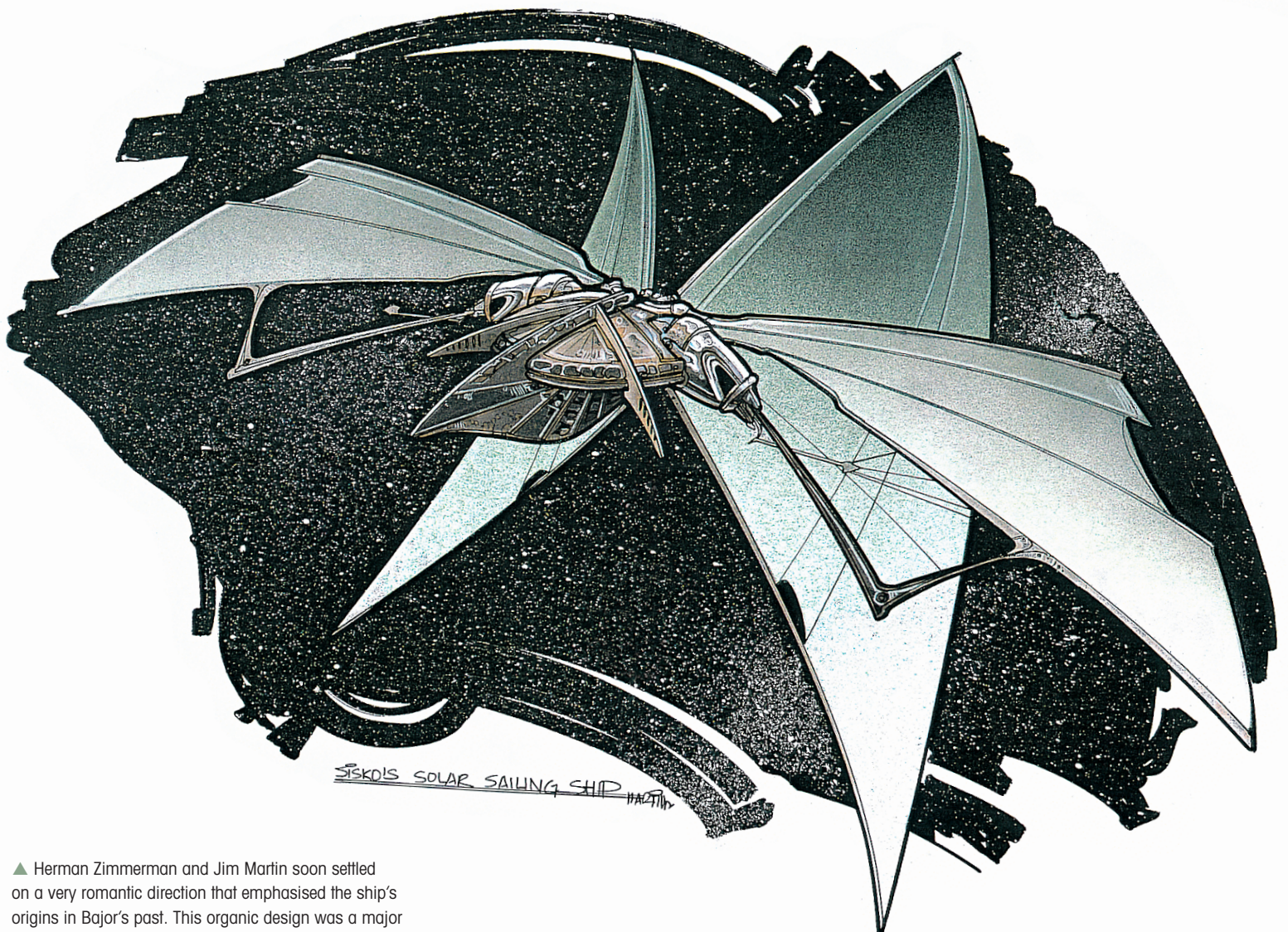

▲ Herman Zimmerman and Jim Martin soon settled on a very romantic direction that emphasised the ship’s origins in Bajor’s past. This organic design was a major departure from the ship’s normally seen in *STAR TREK*.

▼ Herman Zimmerman and Jim Martin made one final modification to their design, adding a jib sail to the top of the ship. This way, the small, turtle-like capsule was surrounded by sails, making the design very efficient.

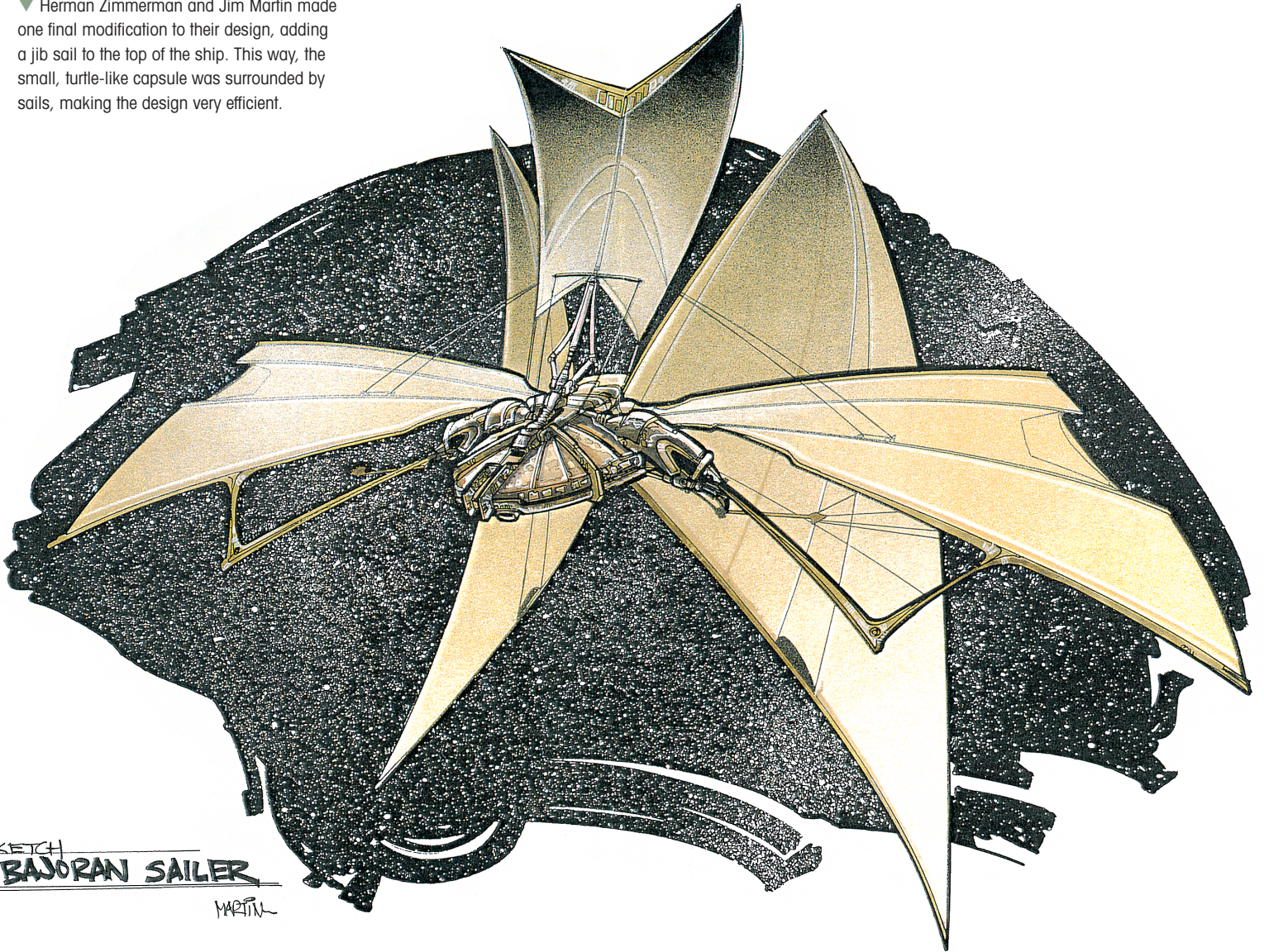

MAIN MAST

▼ This drawing was part of the plans used in the show when Sisko discovered the blueprints of the solar-sailer in the Bajoran library.

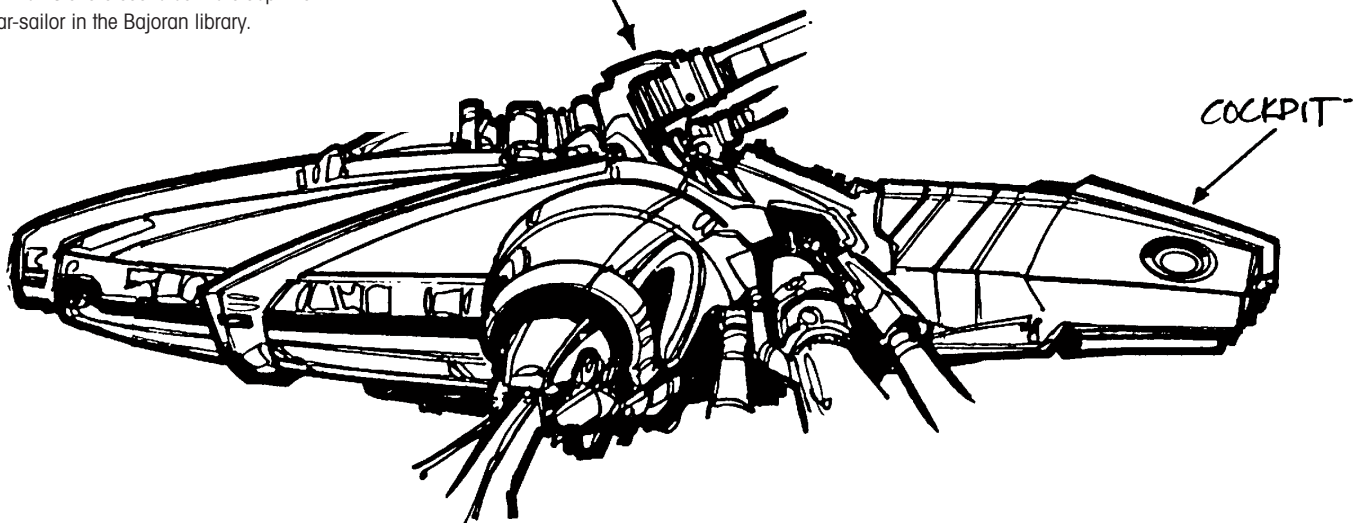

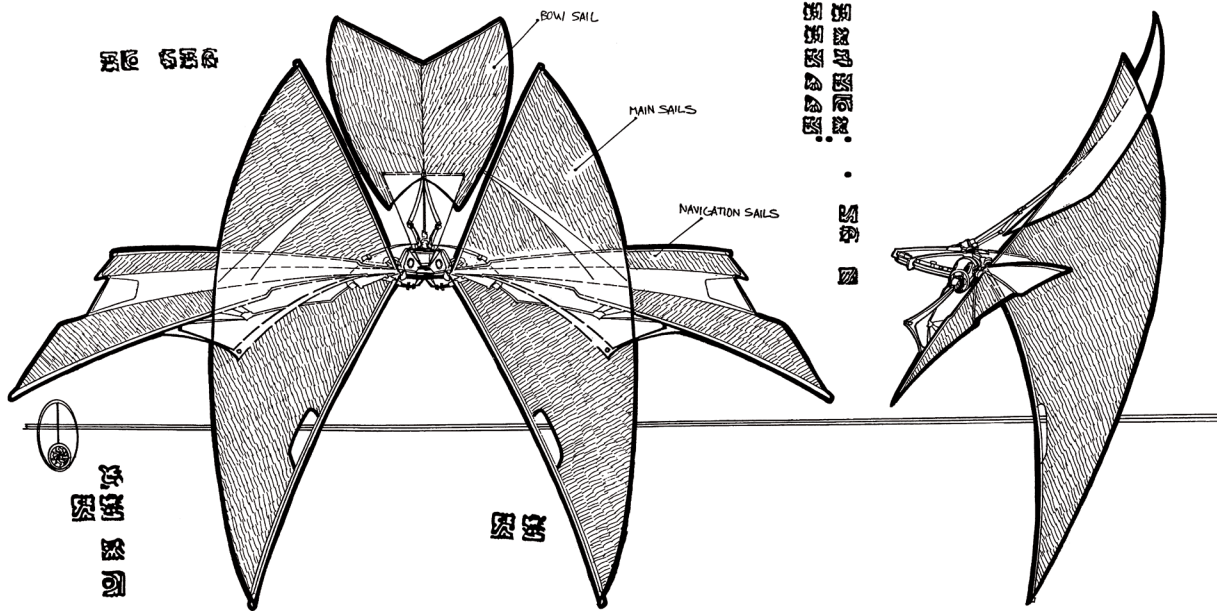

◀ The art department created the plans of the ship that Sisko found in the library by transferring Jim Martin's original drawings and adding some Bajoran symbols, including the ancient text.

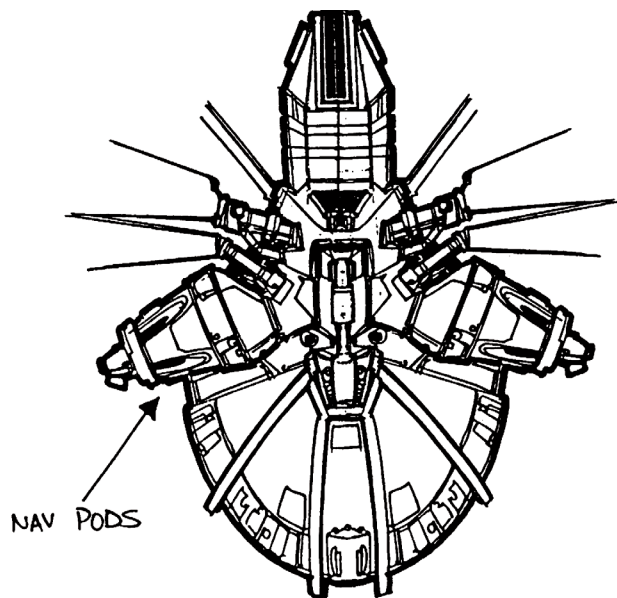

◀ The Bajoran plans depicted the main body of the ship on its own minus the enormous sails. Jim Martin described the solar-sailor as being like a "Bajoran turtle with gossamer wings".

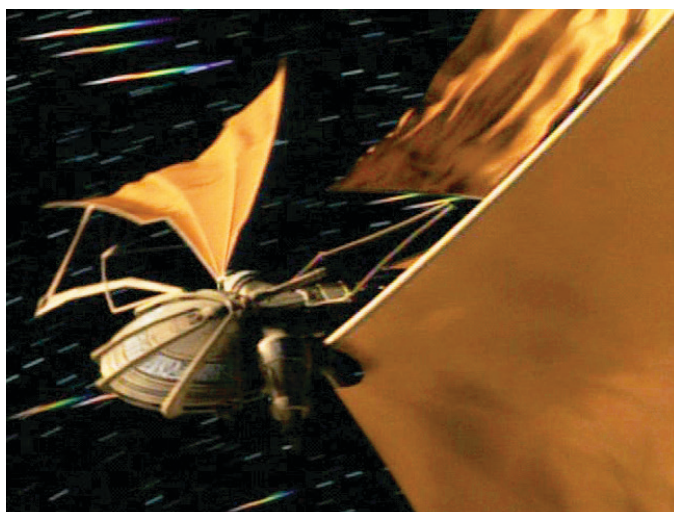

we didn't address that at all. That was handled entirely by the digital department."

ONE OF A KIND

Zimmerman and Martin both named the finished ship as a personal favourite, though Martin said that might be because it was not seen again. "When it's a one-show ship, maybe you like the design a little bit more in one sense because you get nostalgic and think, 'It's too bad we can't use it again.'"

◀ The CGI version of the Bajoran solar-sailor was created by John Knoll at Industrial Light & Magic. The computer effects were particularly good at making the sails ripple and billow.

ON SCREEN



TRIVIA

Leeta, the dabo girl who eventually goes on to marry Rom, makes her first appearance in 'Explorers'. Chase Masterson, the actress who plays her, originally auditioned to play the role of Mardah, Jake Sisko's girlfriend. When she was turned down for that part, she was instead cast as Leeta, who was originally intended to be just a one-episode character. The producers were so impressed with her performance that they decided to make Leeta one of the recurring characters of the show beginning in season four.



René Echevarria, the writer of 'Explorers', told production designer Herman Zimmerman that the solar-sailor should have a "Jules Verne look with a wooden cabin outfitted with brass". To achieve this, Zimmerman added some real sailing equipment to the interior of the ship.

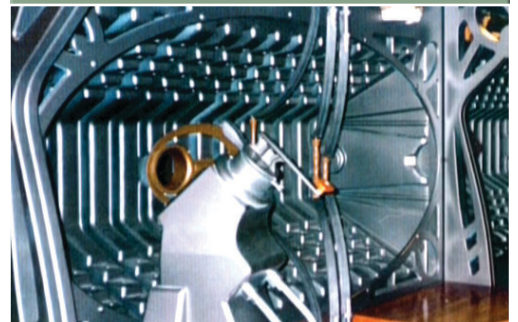

The solar-sailor was recognised as "the most imaginative use of a vehicle to travel in space" and awarded the "Vision of the Future" award by the Space Frontier Foundation in 1995. The award was presented by Robert Staehle, the world's foremost expert on solar sails.

FIRST APPEARANCE:	'EXPLORERS' (DS9)	
MOVIE APPEARANCES:	None	
TV APPEARANCES:	STAR TREK: DEEP SPACE NINE	
DESIGNED BY:	Jim Martin	

KEY APPEARANCE

STAR TREK: DEEP SPACE NINE 'EXPLORERS'

While visiting the reopening of a library on Bajor, Sisko comes across blueprints of an old solar-sailing vessel that the Bajorans used 800 years earlier to explore their star system.

Some historians believe that these ships reached as far as Cardassia, even though they did not have warp drive and were merely powered by light pressure from the sun.

Intrigued by the ancient vessels, Sisko decides to recreate one and take his son, Jake, on a journey to see just how far they can travel in it.

Upon its launch, Sisko and Jake crank the winches to deploy the sails and the ship sails serenely away, proving that the design works.

Sisko and Jake are enjoying the adventure immensely when first one of the spritsails breaks, and shortly after a mainsail is torn off as the ship accelerates to faster-than-light speeds. When the ship drops out of warp, it is badly damaged and Sisko has no idea where they are.

Adrift in space, Jake suddenly spots Cardassian warships approaching. His concern then turns to delight when Gul Dukat congratulates them for making it all the way to Cardassian space.

COMING NEXT

U.S.S. STARGAZER



EVERY
FORTNIGHT
AT YOUR
NEWSAGENT



Inside your magazine

- In-depth profile of the *U.S.S. Stargazer* NCC-2893, Jean-Luc Picard's first command
- The story behind the four-nacelle design of the *U.S.S. Stargazer*
- How the model of the ship was created and filmed

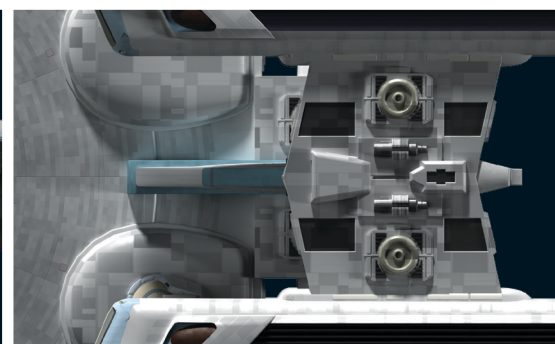
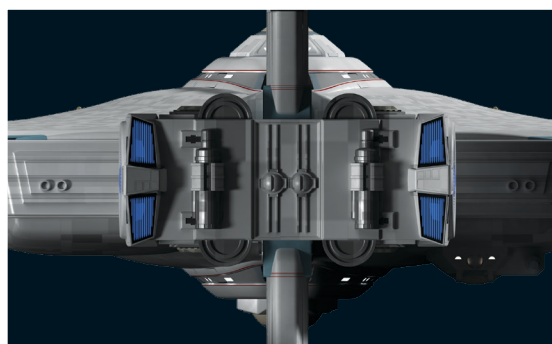
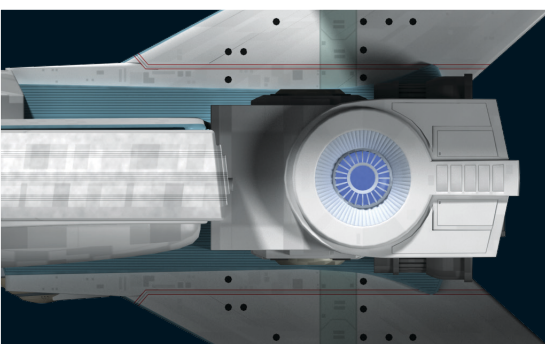

www.startrek-starships.com

STAR TREK™

